

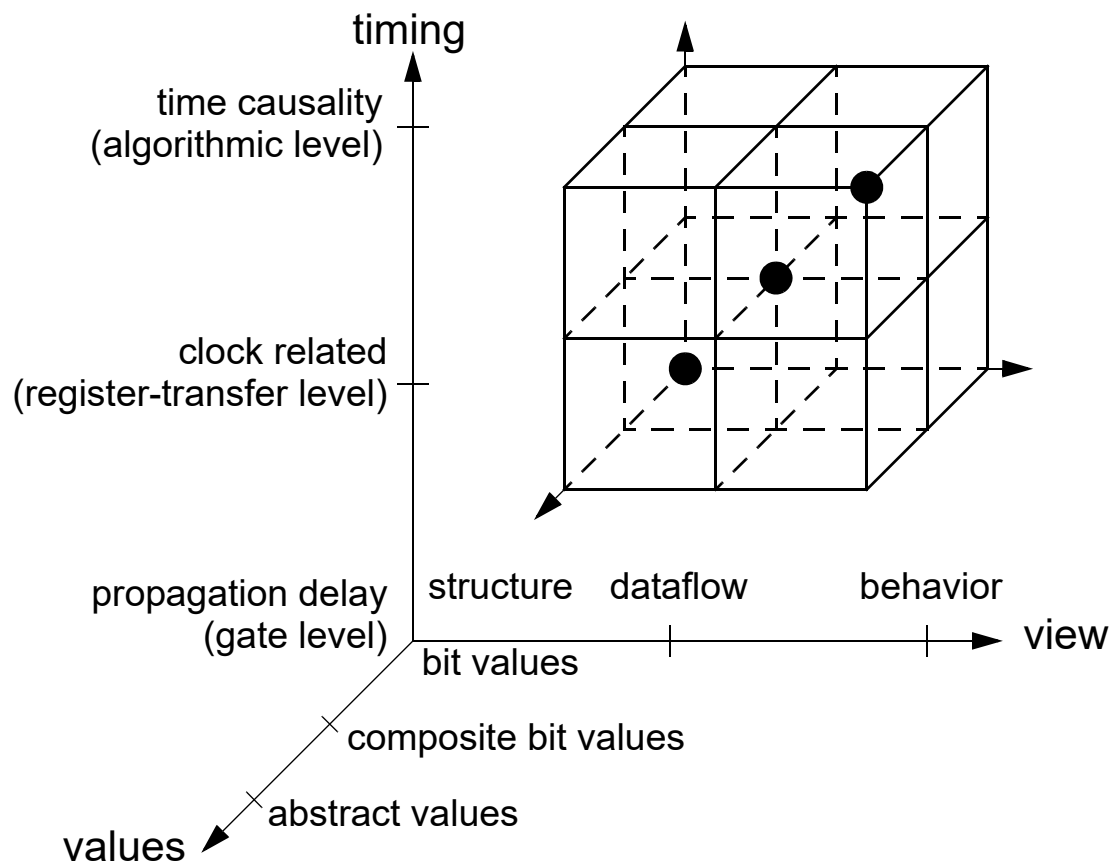

HDL Design Cube





Synthesis and VHDL

- **VHDL LRM defines only simulation semantics of the language.**
- **LRM – Language Reference Manual**

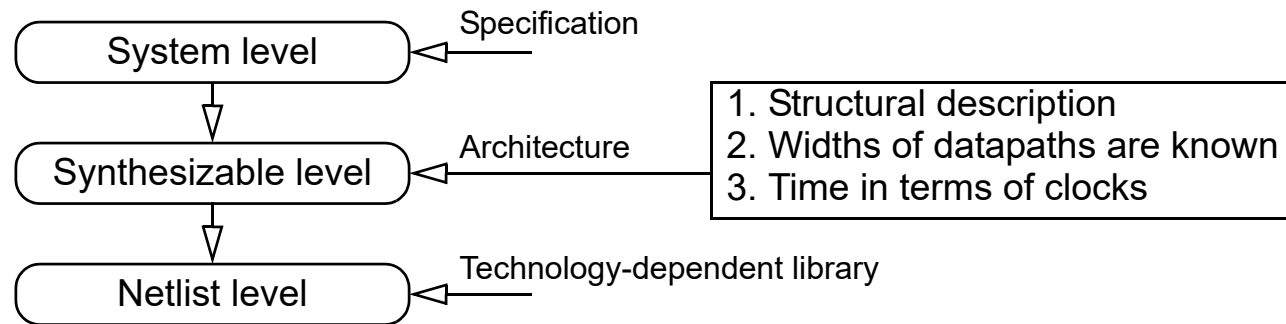

- **Synthesis restrictions:**
 - **the lack of maturity of synthesis tools**
 - **the state-of-art in synthesis targets RTL synthesis only**
 - **certain VHDL features are simply not synthesizable**



Synthesis style

- Delay expressions (*after* clauses, *wait for* statements are ignored)
- Certain restrictions on the writing of process statement occur
- Only a few types are allowed
 - integer, enumerated, e.g., bit, bit_vector, signed
- Type conversion and resolution functions are not interpreted
- Description is oriented towards synchronous styles with explicit clocks
- Types: enumeration, integer, one-dimensional array, record
 - type WORD is array (31 downto 0) of BIT;
 - type RAM is array (1023 downto 0) of WORD;
- In record, an item address becomes hardware coded
- **!!! Time type is not supported !!!**
- No explicit or default initialization
- Parenthesis in expressions have effect on HW generation
- Some arithmetic operations are supported partially only



Sensitivity list

- **Equivalent processes:**

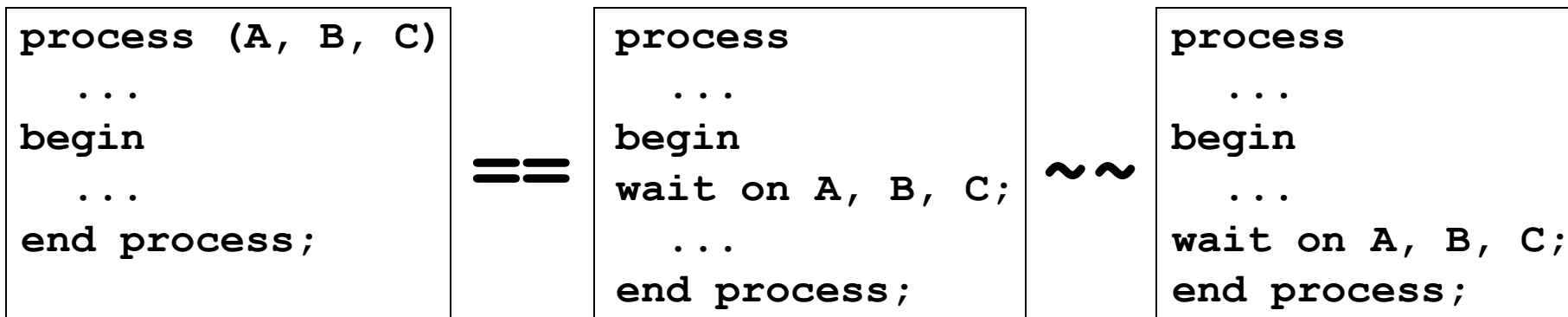

- **Some synthesizers support only sensitivity list for combinational logic**
- **In case of single synchronization process there is no need to “remember” at which synchronization point it was stopped → such behavior does not imply memorization**
- **Process with multiple synchronization points, i.e. several wait states, infer memorization – FSM**

Assignment statement synthesis

```

signal A,B: BIT_VECTOR(0 to 3);
signal I: INTEGER range 0 to 3;
signal Y,Z: BIT;
-- . . .
process ( I, Y, Z ) begin
  A<="0000";
  B<="0000";
  A(I)<=Y;  -- Computable index
  B(3)<=Z;  -- Constant index
end process;
  
```

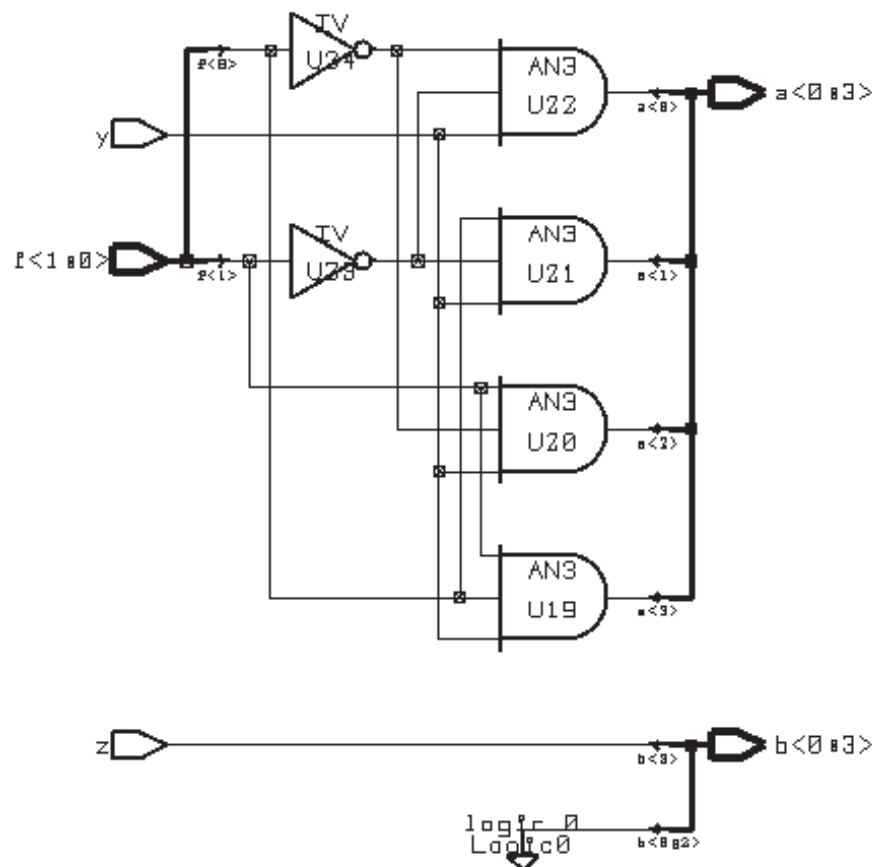

if statement synthesis

```

signal A,B,C,P1,P2,Z: BIT;
-- . . .
process (P1,P2,A,B,C) begin
  if (P1 = '1') then
    Z <= A;
  elsif (P2 = '0') then
    Z <= B;
  else
    Z <= C;
  end if;
end process;
  
```

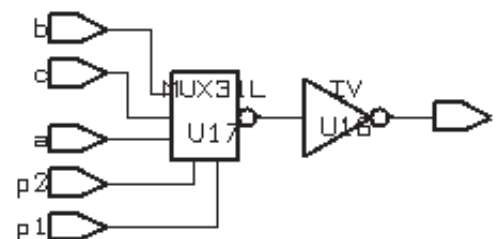
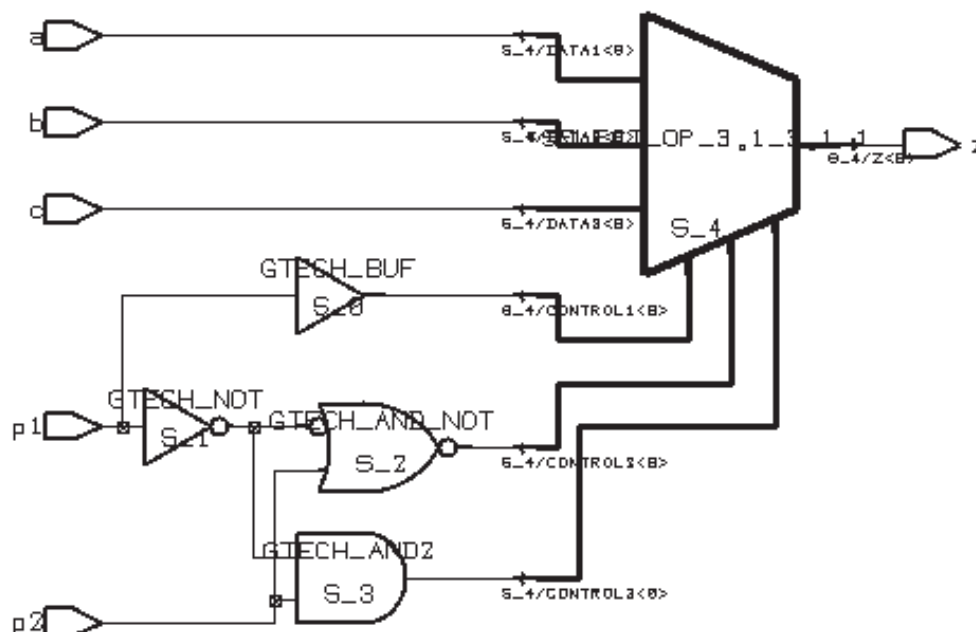

SR latch

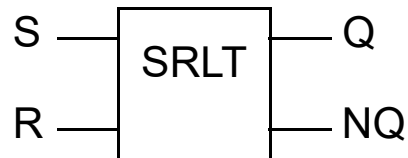

```

use WORK.CHECK_PKG.all;
entity SRLT is
    port ( S, R:  in bit;
          Q, NQ: out bit );
begin
    NOT_AT_THE_SAME_TIME(S,R);
end SRLT;
  
```

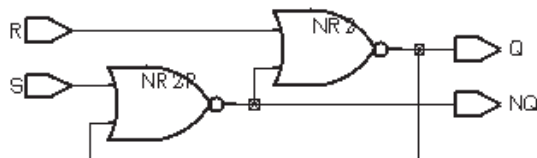

```

architecture A1 of SRLT is
    signal LQ:  bit := '1';
    signal LNQ: bit := '0';
begin
    LNQ <= S nor LQ;
    LQ  <= R nor LNQ;
    Q   <= LQ;
    NQ  <= LNQ;
end A1;
  
```

- **NB! Asynchronous feed-back is temporarily cut by synthesizers...**



Combinational circuit

- **A process is combinational, i.e. does not infer memorization, if:**
 - **the process has an explicit sensitivity list or contains a single synchronization point (waiting for changes on all input values); ¹⁾**
 - **no local variable declarations, or variables are assigned before being read;**
 - **all signals, which values are read, are part of the sensitivity list; ²⁾ and**
 - **all output signals are targets of signal assignments independent on the branch of the process, i.e. all signal assignments are covered by all conditional combinations.**
- 1) waiting on a clock signal, e.g., “ wait on clk until clk='1'; ”, implies buffered outputs (FF-s)**
- 2) interpretation may differ from tool to tool**

Complex assignments

- No memory

```
S <= A when X='1' else B when Y='1' else C;
```

```
process (A, B, C, X, Y) begin
  if X='1' then S <= A;
  elsif Y='1' then S <= B;
  else S <= C;
  end if;
end process;
```

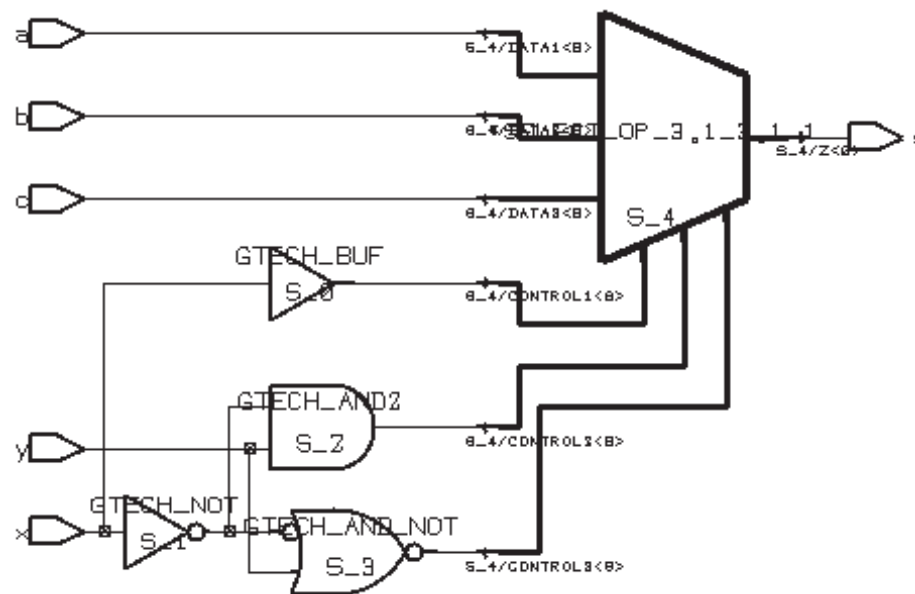
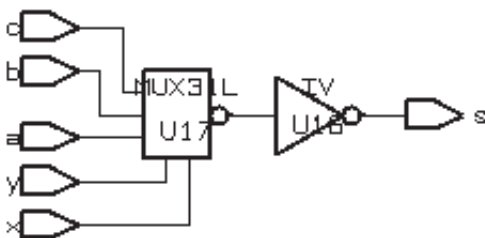

Complex assignments (#2)

- **Memory element generated!**

```

process (A, B, X, Y) begin
  if X='1' then S <= A;
  elsif Y='1' then S <= B;
  end if;
end process;
  
```

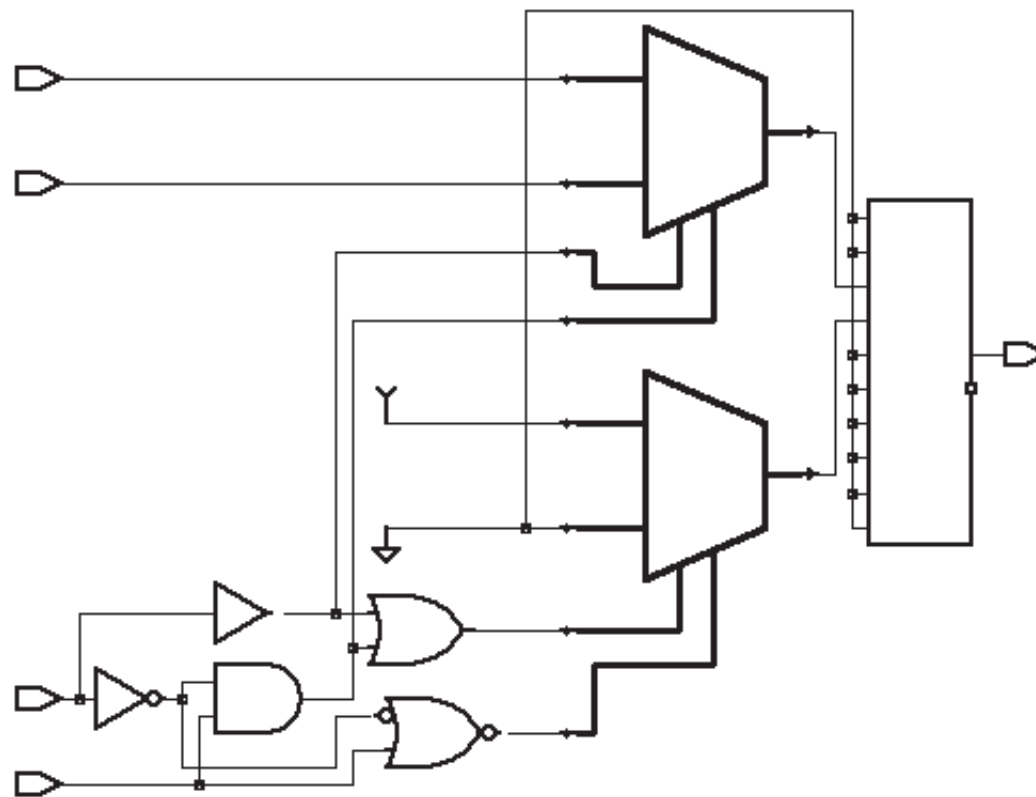
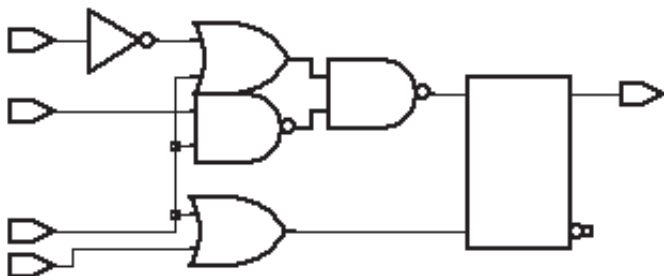

Complex assignments (#3)

- **Memory element generated!**

```
S <= A when X='1' else B when Y='1' else S;
```

```
process (A, B, X, Y) begin
  if X='1' then S <= A;
  elsif Y='1' then S <= B;
  else S <= S;
  end if;
end process;
```

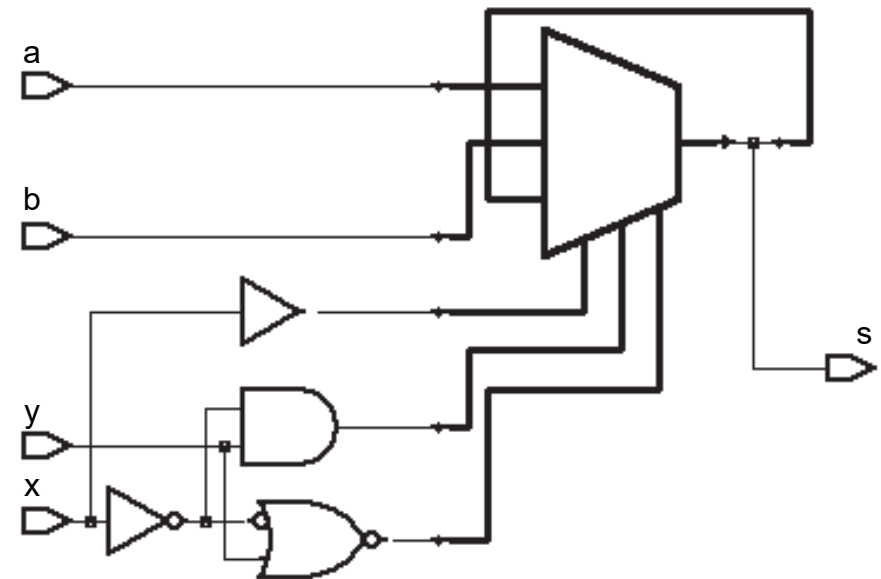
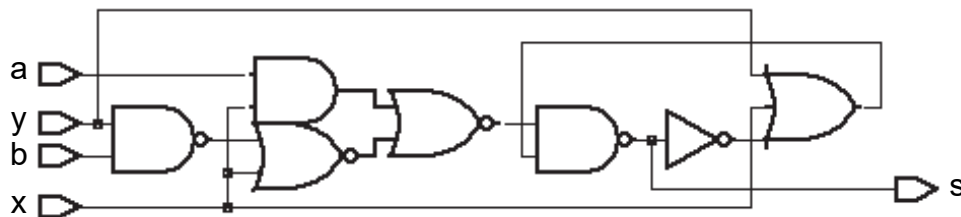

Default values

- The default values inherited from type or subtype definitions
- The explicit initialization that is given when the object is declared
- A value assigned using a statement at the beginning of a process
- Only the last case is supported by synthesis tools!
- Usually, a part of the synthesizable code is devoted to *set/reset* constructions
- Default values can be used to guarantee that the signal always gets a new value

```

process (A, B, X, Y) begin
  S <= '0';
  if X='1' then S <= A;
  elsif Y='1' then S <= B;
  end if;
end process;
  
```

```

process (A, B, X, Y) begin
  S <= '-';
  if X='1' then S <= A;
  elsif Y='1' then S <= B;
  end if;
end process;
  
```

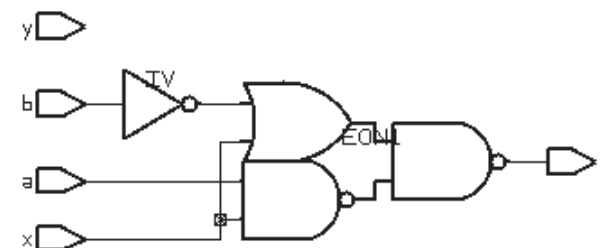
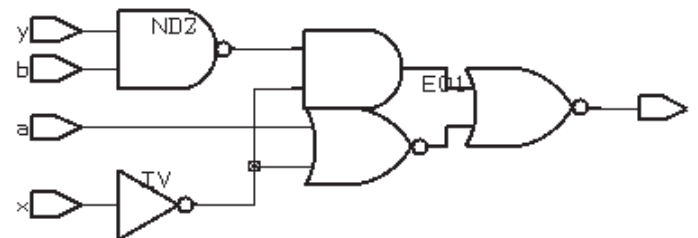

Flip-flops

- **Process with the clock signal in the sensitivity list and explicit clock flank definition**

```
process (CLK) begin
  if CLK='1' and CLK'event then    Q <= D;    end if;
end process;
```

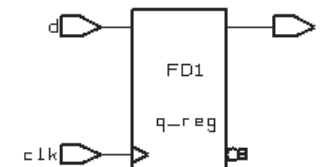

- **Process with the clock signal and clock flank definition in the wait statement**

```
process begin
  wait on CLK until CLK='1';    Q <= D;
end process;
```

- **Concurrent assignment with the clock signal and clock flank definition**

```
Q <= D when CLK='1' and CLK'event;
```

- **Asynchronous reset & synchronous enable**

```
process (RES,CLK) begin
  if RES='1' then    Q <= '0';    -- asynchronous reset
  elsif CLK='1' and CLK'EVENT then
    if ENA='1' then    Q <= D;    end if;
  end if;
end process P4_FF;
```

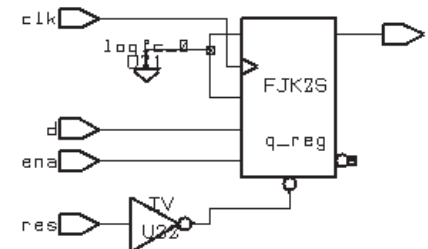

Latch vs. Flip-flop?

```
P1_L: process (CLK, D) begin
    if CLK='1' then      Q <= D;
    end if;
end process P1_L;
```

```
P2_FL: process (CLK) begin
    if CLK='1' then      Q<=D;
    end if;
end process P2_FL;
```

```
P1_FF: process (CLK) begin
    if CLK='1' and
        CLK'event then  Q<=D;
    end if;
end process P1_FF;
```

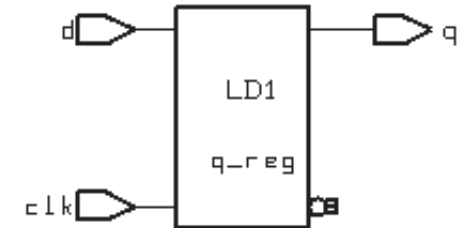

- **Simulation OK but not synthesis!**
 - Warning: Variable 'd' is being read
 - in routine .. line .. in file '..',
 - but is not in the process sensitivity
 - list of the block which begins
 - there. (HDL-179)
- **Result - latch**

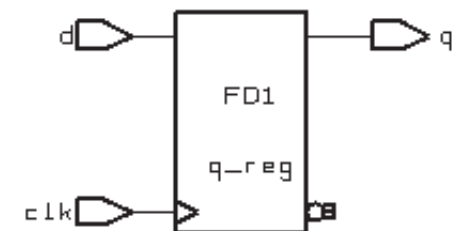



Synthesis rules

- **Guidelines in priority order:**
 - the target signal(s) will be synthesized as flip-flops when there is a signal edge expression, e.g. CLK'event and CLK='1', in the process
 - usually, only one edge expression is allowed per process
 - different processes can have different clocks (tool depending)
 - the target signal will infer three-state buffer(s) when it can be assigned a value 'Z'
 - example: `Q <= D when SEL='1' else 'Z';`
 - the target signal will infer a latch (latches) when the target signal is not assigned with a value in every conditional branch, and the edge expression is missing
 - a combinational circuit will be synthesized otherwise
- It is a good practice to isolate flip-flops, latches and three-state buffers inferences to ensure design correctness

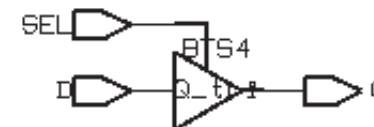

Signal versus variable

- The hardware resulting from synthesis of variables or signals differs: either nothing, wires, or memory elements

```

signal A1, A2: BIT;
-- . . .
process (CLOCK)
  variable A3: BIT;
begin
  if CLOCK='1' and CLOCK'event then
    A3 := A1 and A2;
    Z <= A3;
  end if;
end process;
  
```

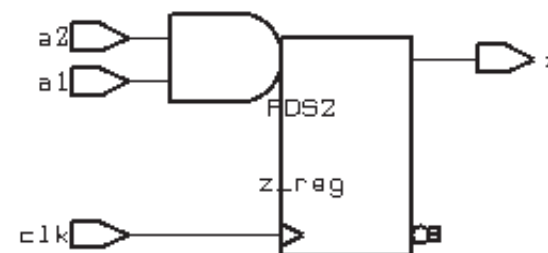

```

signal A1, A2, A3: BIT;
-- . . .
process (CLOCK)
begin
  if CLOCK='1' and CLOCK'event then
    A3 <= A1 and A2;    -- Next delta-cycle!!
    Z <= A3;
  end if;
end process;
  
```

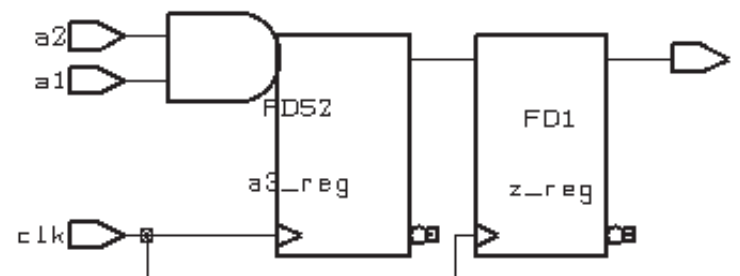

Data-part & control-part

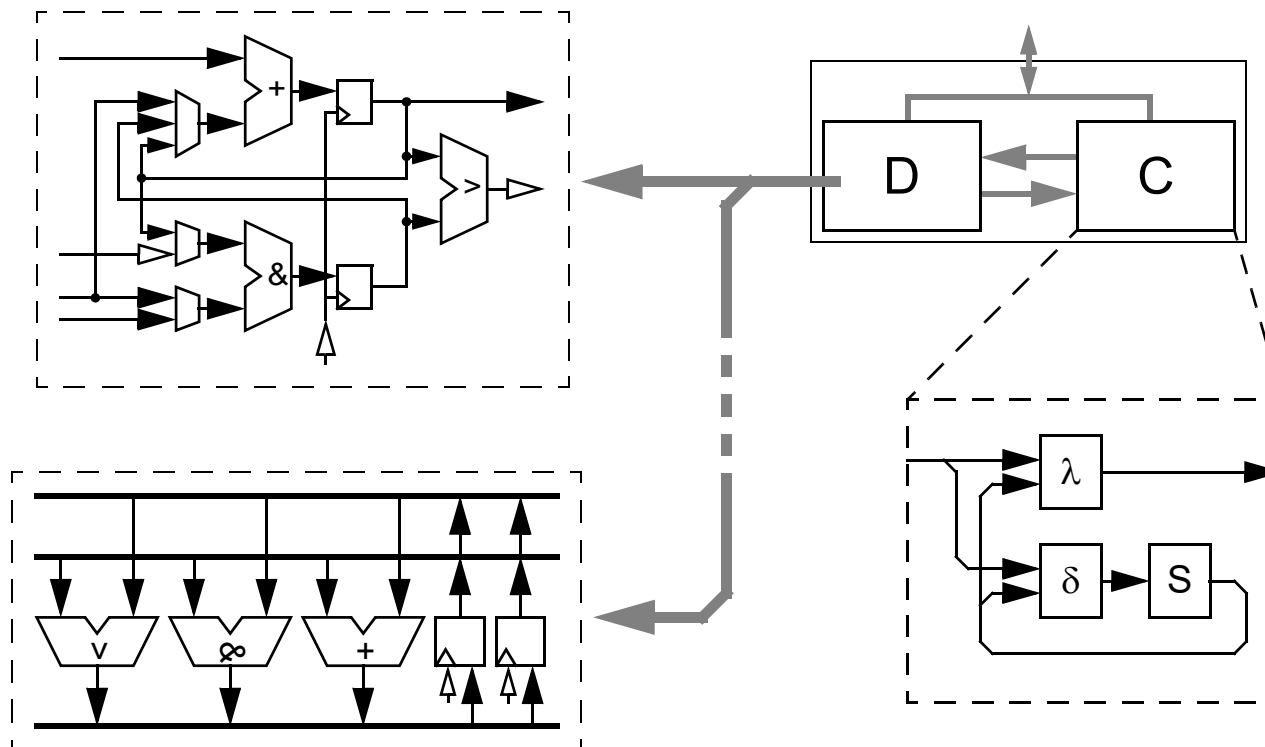

- **one unit – one process**

- **functional units – combinational processes**
- **storage units – clocked processes**

[all inputs in the sensitivity list]

[activation at clock edge]

FSM in VHDL

- **FSM:** $M = (S, I, O, \delta, \lambda)$
 - **S:** set of states
 - **I:** set on inputs
 - **O:** set of outputs
 - δ : transition function - $\delta: S \times I \rightarrow S$
 - λ : output function - $\lambda: S \times I \rightarrow O$

- **How many processes?**

- Process per block

- **Three processes**

- (1) transition function, (2) output function, (3) state register

- **Two processes**

- (1) merged transition and output functions, (2) state register [Mealy]

- **One process**

- buffered outputs! [Moore]

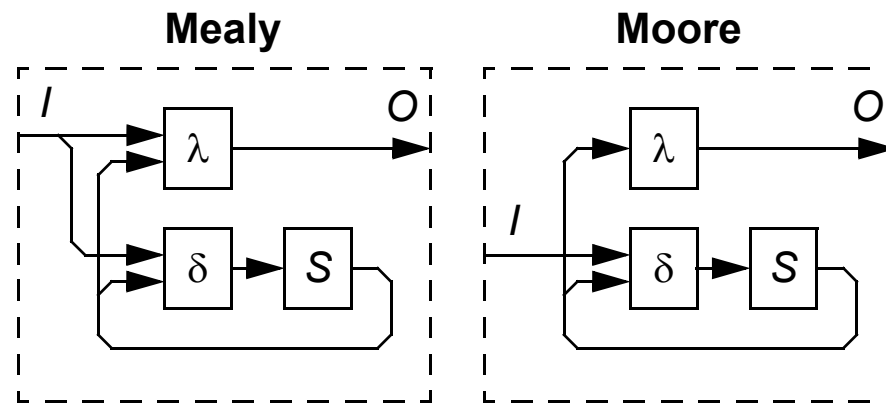



FSM as a single process

- Note that all signals assigned in the process will have flip-flops!

```
-- RESET is the asynchronous reset, CLK is the clock
-- STATE is a variable (or signal) memorizing the current state
process (RESET,CLK)
begin
    if RESET='1' then                -- asynchronous reset
        STATE <= S_INIT;
    elsif CLK='1' and CLK'EVENT then
        case STATE is
            when S_INIT => if I0='1' then STATE <= S5; end if;
            when ... => ...
        end case;
    end if;
end process;
```



Three process FSM

- **storage elements, transition function & output function**

architecture B of FSM is

```
    type TYPE_STATE is (S_INIT,S1,...Sn);
    signal CURRENT_STATE, NEXT_STATE : TYPE_STATE;
begin
    P_STATE: process begin -- sequential process / storage elements
        wait until CLK'EVENT and CLK='1';
        if RESET ='1' then CURRENT_STATE <= S_INIT;
        else
            CURRENT_STATE <= NEXT_STATE; end if;
    end process P_STATE;
    P_NEXT_STATE: process (I0, ..., CURRENT_STATE) begin -- next state function
        NEXT_STATE <= CURRENT_STATE;
        case CURRENT_STATE is
            when S_INIT => if I0='1' then NEXT_STATE <= S5; end if;
            when ... => ...
        end case;
    end process P_NEXT_STATE;
    P_OUTPUTS: process (CURRENT_STATE) begin -- output function
        case CURRENT_STATE is
            when S_INIT => O <= '0';
            when ... => ...
        end case;
    end process P_OUTPUTS;
end B;
```



FSM #2 – description styles & synthesis

Two processes (modulo-4 counter)

```

library IEEE; use IEEE.std_logic_1164.all;
entity counter03 is
  port ( clk: in bit;
         resetn: in std_logic;
         three: out std_logic );
end entity counter03;
architecture fsm2 of counter03 is
  subtype state_type is integer range 0 to 3;
  signal pres_state, next_state: state_type := 0;
begin
  process (clk) begin -- State memory
    if clk'event and clk = '1' then
      pres_state <= next_state;
    end if;
  end process;
  -- Next state & output functions
  process (resetn, pres_state) begin
    three <= '0';
    if resetn='0' then      next_state <= 0;
    else
      case pres_state is
        when 0 to 2 => next_state <= pres_state + 1;
        when 3 => next_state <= 0;  three <= '1';
      end case;
    end if;
  end process;
end architecture fsm2;

```

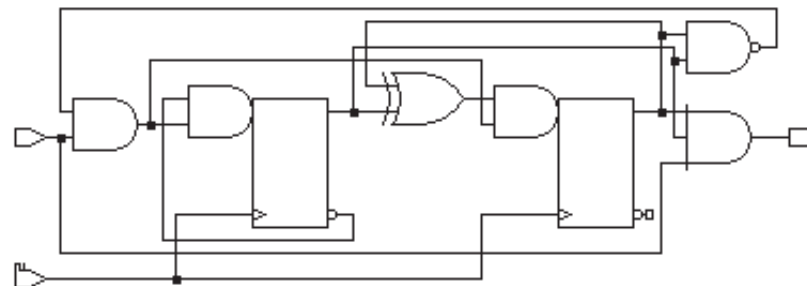
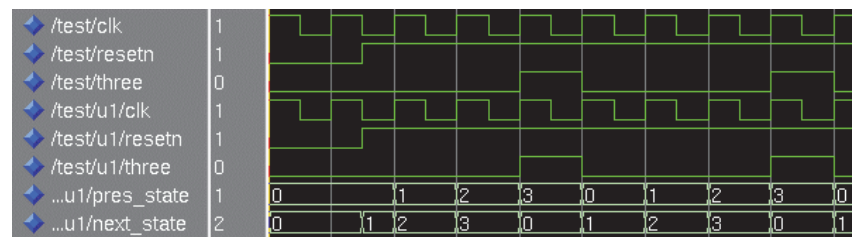

22 gates / 3.70 ns



FSM #2 – description styles & synthesis

Three processes (modulo-4 counter)

```

library IEEE; use IEEE.std_logic_1164.all;
architecture fsm3 of counter03 is
  subtype state_type is integer range 0 to 3;
  signal pres_state, next_state: state_type := 0;
begin
  process (clk) begin -- State memory
    if clk'event and clk = '1' then
      pres_state <= next_state;
    end if;
  end process;

  -- Next state function
  process (resetn, pres_state) begin
    if resetn='0' then next_state <= 0;
    else
      if pres_state=3 then next_state <= 0;
      else next_state <= pres_state + 1;
      end if;
    end if;
  end process;

  -- Output function
  process (resetn, pres_state) begin
    if pres_state=3 then three <= '1';
    else three <= '0';
    end if;
  end process;
end architecture fsm3;

```

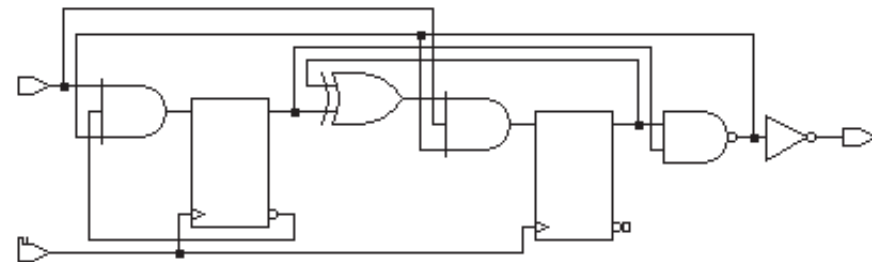
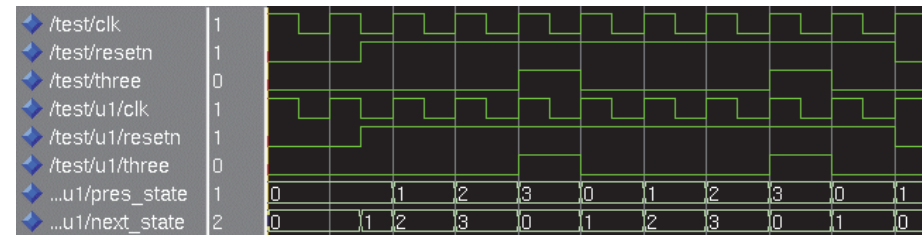

23 gates / 4.36 ns

FSM #2 – description styles & synthesis

One process (modulo-4 counter)

```

library IEEE; use IEEE.std_logic_1164.all;
architecture fsm1 of counter03 is
  subtype state_type is integer range 0 to 3;
  signal state: state_type := 0;
begin
  process (clk) begin
    if clk'event and clk = '1' then
      three <= '0';
      if resetn='0' then    state <= 0;
      else
        case state is
          when 0 | 1 => state <= state + 1;
          when 2 => state <= state + 1;  three <= '1';
          when 3 => state <= 0;
        end case;
      end if;
    end if;
  end process;
end architecture fsm1;
  
```

```

// Another version to build the process
process begin
  wait on clk until clk='1';
  three <= '0';
  if resetn='0' then    state <= 0;
  else
    -- and so on...
  end if;
end process;
  
```

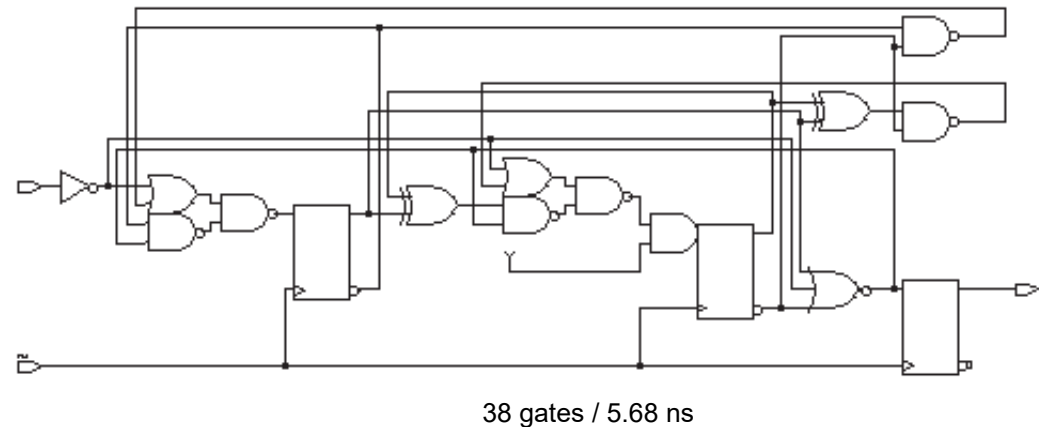
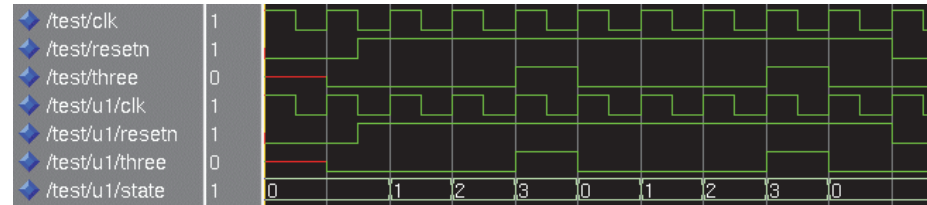

Don't care values and synthesis

```

process (A, B, SEL) begin
  case SEL is
    when "001" =>    X <= A;
    when "010" =>    X <= B;
    when others =>    X <= '-';
  end case;
end process;
  
```

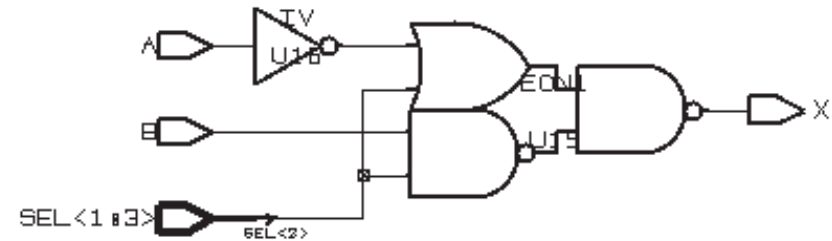

Using generics

```

entity AND_N is
  generic (N: POSITIVE);    port (DIN: in BIT_VECTOR(1 to N); R: out BIT);
end AND_N;
architecture A1 of AND_N is
  signal INTER: BIT_VECTOR(1 to N);
begin
  INTER(1) <= DIN(1);
  L: for I in 1 to N-1 generate  INTER(I+1) <= DIN(I+1) and INTER(I);
  end generate;
  R <= INTER(N);
end A1;

C1: AND_N generic map (N=>12) port map(IN_DATA, OUT_DATA);
  
```



Arithmetics

- **Overloaded arithmetic operations:**

```
library IEEE;
use IEEE.std_logic_1164.all;
use IEEE.std_logic_arith.all;
```

- **Sources of the named packages are in the directory:
\$SYNOPSYS/packages/IEEE/src**

- **\$SYNOPSYS/packages is the root directory for all Synopsys packages**
- **Be careful with '*', '/', '**' - extremely chip area consuming**
 - **Safe in some special cases - multiplication by power of two**
- **Use parenthesis to group a set of gates**
- **What you write is what you'll get!**

Behavioral RTL vs. “pure” RTL

```

library IEEE;
use IEEE.std_logic_1164.all;
use IEEE.std_logic_arith.all;
entity test is
  port ( a, b, c: in unsigned(7 downto 0);
        x: in unsigned(2 downto 0);
        o: out unsigned(7 downto 0) );
end test;
architecture bhv of test is begin
process (a, b, c, x)
  constant x2: unsigned(2 downto 0) := "010";
  constant x3: unsigned(2 downto 0) := "011";
  constant x6: unsigned(2 downto 0) := "110";
begin
  if    x=x2 then  o <= a+b;
  elsif x=x3 then  o <= a+c;
  elsif x=x6 then  o <= b+c;
  else             o <= (others=>'0');
  end if;
end process;
end architecture bhv;
  
```

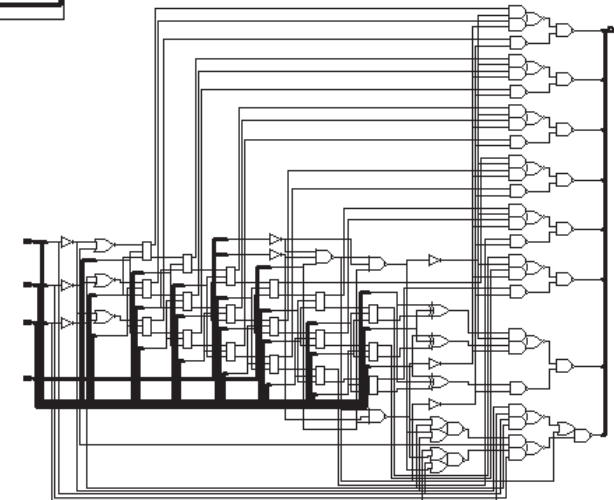
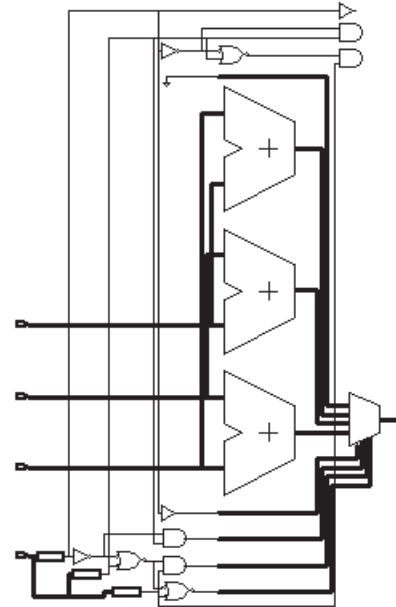

220 gates / 11.57 ns

Behavioral RTL vs. “pure” RTL

```

architecture bhv2 of test is begin
process (a, b, c, x) begin
  case x is
    when "010" => o <= a+b;
    when "011" => o <= a+c;
    when "110" => o <= b+c;
    when others => o <= (others=>'0');
  end case;
end process;
end architecture bhv2;
  
```

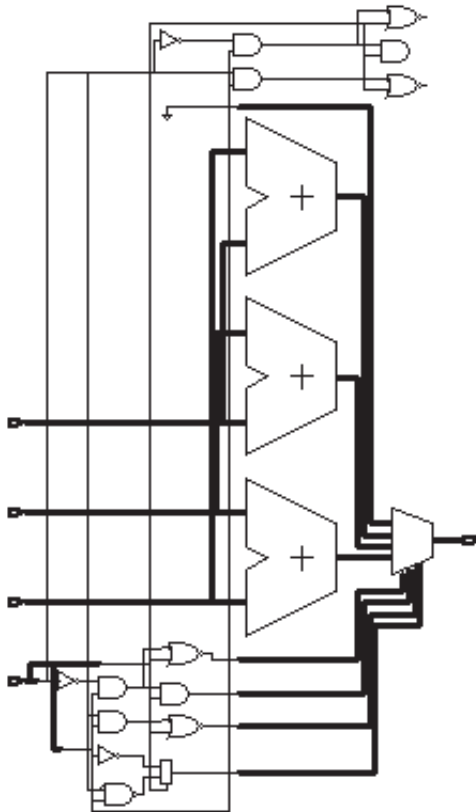

220 gates / 11.57 ns

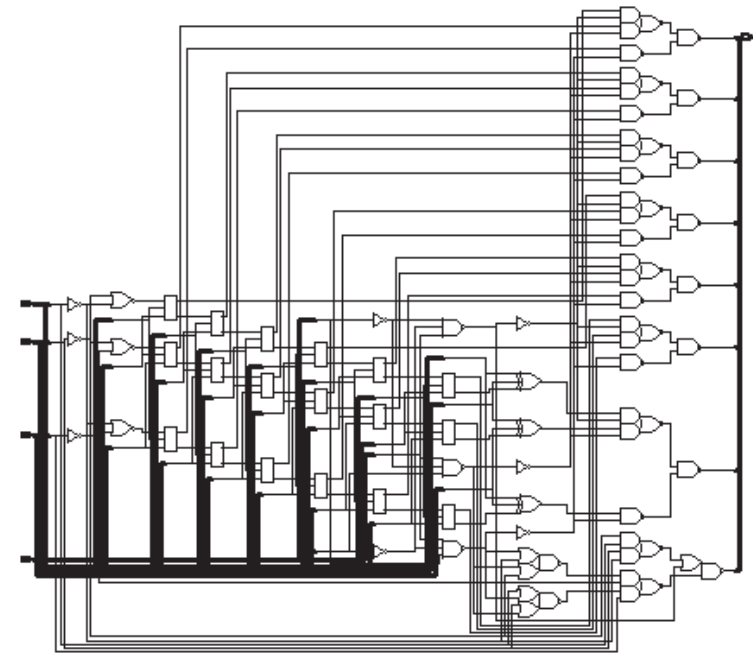

Behavioral RTL vs. “pure” RTL

```

architecture rtl of test is
  signal a1, a2: unsigned(7 downto 0);
  signal dc: unsigned(1 downto 0);
begin
  dec: process (x) begin
    case x is
      when "010" => dc <= "01";
      when "011" => dc <= "10";
      when "110" => dc <= "11";
      when others => dc <= "00";
    end case;
  end process dec;
  m1: process (a, b, dc) begin
    case dc is
      when "01" => a1 <= a;
      when "10" => a1 <= a;
      when "11" => a1 <= b;
      when others => a1 <= (others=>'0');
    end case;
  end process m1;
  m2: process (b, c, dc) begin
    -- ...
  end process m2;
  o <= a1 + a2;
end architecture rtl;
  
```

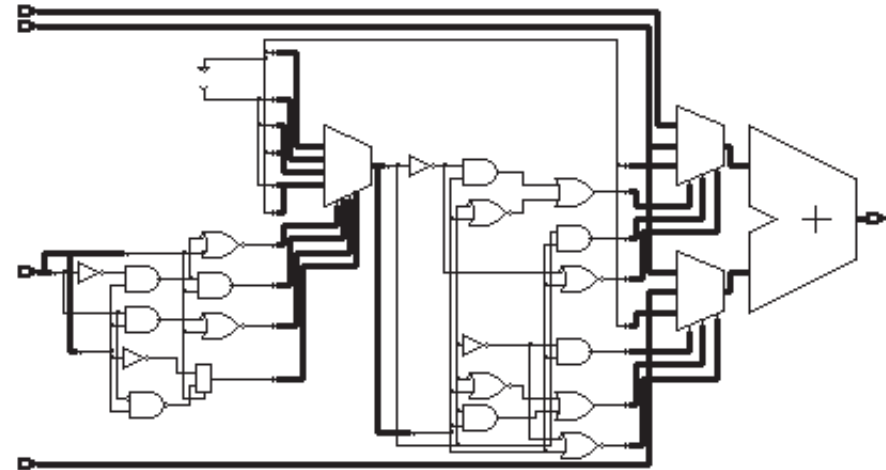

117 gates / 19.2 ns

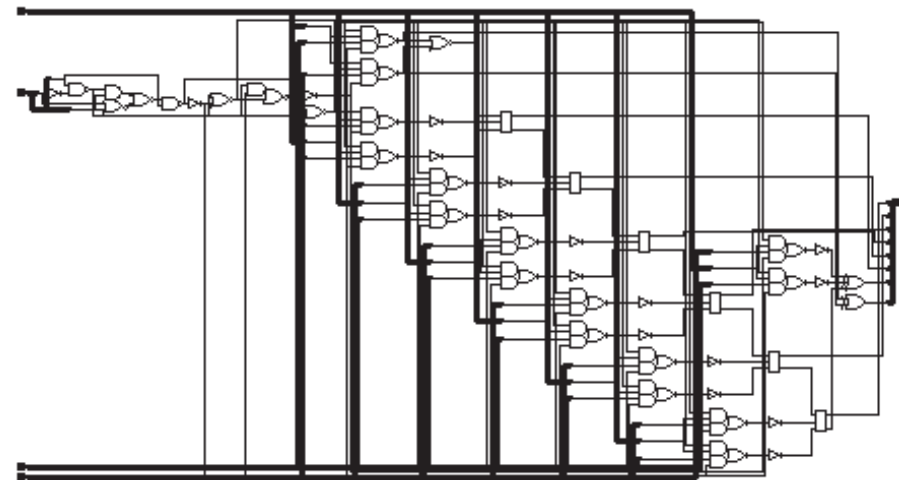



Adder / Subtractor

```
library IEEE;
use IEEE.std_logic_1164.all;
use IEEE.std_logic_arith.all;
entity add_sub is
  port ( a, b: in unsigned(7 downto 0);
        x: in std_logic;
        o: out unsigned(7 downto 0) );
end add_sub;
architecture bhv of add_sub is begin
process (a, b, x) begin
  if x='0' then o <= a+b;
  else          o <= a-b; end if;
end process;
end architecture bhv;
```

Adder, subtractor & mux

145 gates / 11.64 ns

```
architecture dfl of test5 is
  signal a1, b1, o1: unsigned(8 downto 0);
begin
  a1 <= a & '1';
  b1 <= b & '0' when x='0' else
    unsigned(not std_logic_vector(b)) &
    '1';
  o1 <= a1+b1;
  o <= o1(8 downto 1);
end architecture dfl;
```

87 gates / 12.45 ns

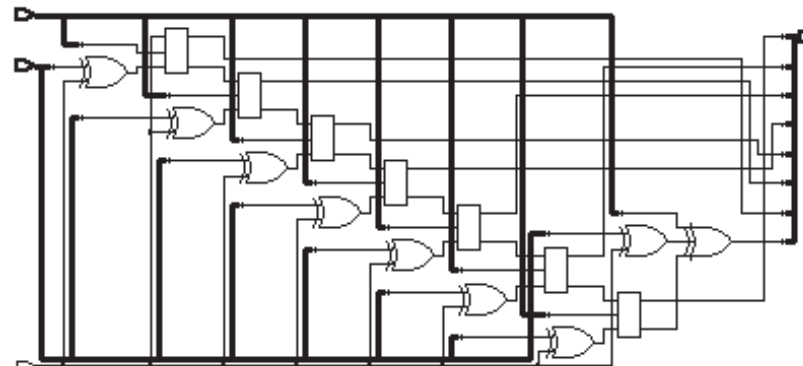

Adders & Subtractors

```

a1 <= '0' & a & '1';
b1 <= '0' & b & ci;
o1 <= a1 + b1;
o <= o1(8 downto 1);
co <= o1(9);
  
```

64 g. / 10.66 ns [60 g. / 10.08 ns w/o ci/co]



```

a1 <= '0' & a & '1';
b1 <= '0' &
  unsigned(not std_logic_vector(b)) & ci;
o1 <= a1 + b1;
o <= o1(8 downto 1);
co <= o1(9);
  
```

72 g. / 10.62 ns [66 g. / 10.35 ns w/o ci/co]

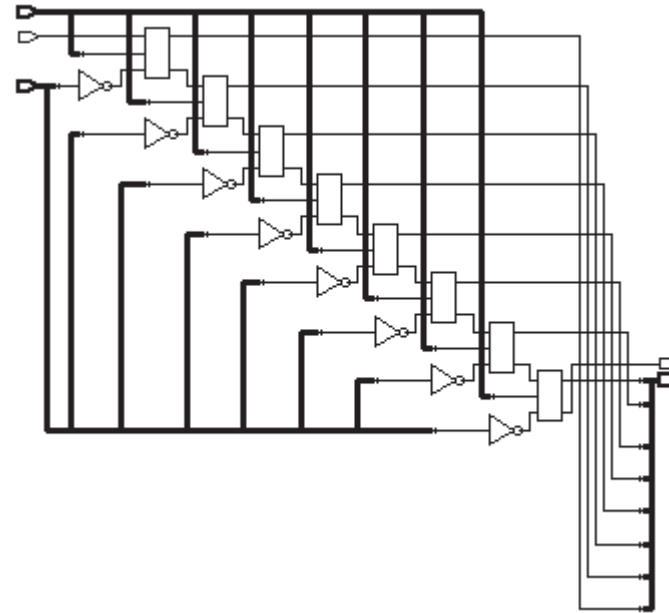



for-loop versus while-loop?

- **May be tool dependent!**

- Design Vision (Synopsys): *for* - parallel, *while* - sequential
- ISE (Xilinx): *for / while* - both parallel
- Leonardo (Mentor Graphics): depending on the timing constructs

- **for-loop**

- parallel implementation
- no timing control (wait) in the loop body

```
for i in 0 to 7 loop
    x(i) := a(i) and b(i);
end loop;
```

- **while-loop**

- sequential implementation
- timing control (wait) required in the loop body

```
i := 0;
while i<7 loop
    data(i) := in_port;
    wait on clk until clk='1';
    i := i + 1;
end loop;
```



Multiple wait statements

- **VHDL semantics must be preserved**
 - different interpretations possible
- **Distributing operations over multiple clock steps**

- **Algorithm**

- **Inputs: a, b, c, d**
- **Output: x**
- **Coefficients: c1, c2**
- **$x = a + b*c1 + c*c2 + d$**
- **Timing constraint - 3 clock periods**

```
process
    variable av, bv, cv, dv: ...;
begin
    av:=a; bv:=b; cv:=c; dv:=d;
    wait on clk until clk='1';
    wait on clk until clk='1';
    x <= av + bv * c1 + cv * c2 + dv;
    wait on clk until clk='1';
end process;
```



Multiple wait statements

- Behavioral interpretation may lead to an unoptimal solution

```

process
  variable av, bv, cv, dv: ...;
begin
  av:=a; bv:=b; cv:=c; dv:=d;
  wait on clk until clk='1';
  wait on clk until clk='1';
  x <= av + bv * c1 + cv * c2 + dv;
  wait on clk until clk='1';
end process;
  
```

2 multipliers & 3 adders

```

process
  variable av, bv, cv, dv: ...;
  variable r1, r2: ...;
begin
  av:=a; bv:=b; cv:=c; dv:=d;
  r1 := av + dv;    r2 := bv * c1;
  wait on clk until clk='1';
  r1 := r1 + r2;    r2 := cv * c2;
  wait on clk until clk='1';
  x <= r1 + r2;
  wait on clk until clk='1';
end process;
  
```

1 multiplier & 1 adder

*Behavioral Synthesis
(High-Level Synthesis)*



Inserting wait statements

- **VHDL semantics preserved for inputs/outputs**
- **targeting as-fast-as-possible (AFAP) schedules**

- **16-tap FIR filter**

- **new input and output data at every rising flank of sys_clk (sampling clock)**
- **internal clock can be added**

- **How to implement loops?**

- **1st - in parallel (shift-register)**
- **2nd - sequentially**
 - **multiply-and-accumulate (MAC)**
 - **ROM for coefficients**

```

process
  variable sum: ...;
  variable buff: ...; -- array (0 to 15)
begin
  for i in 15 downto 1 loop
    buff(i) := buff(i-1);
  end loop;
  buff(0) := data_in;      sum := 0;
  for i in 0 to 15 loop
    sum := sum + buff(i) * coeff(i);
  end loop;
  x <= sum;
  wait on sys_clk until sys_clk='1';
end process;

```



GCD (Greatest Common Divisor) example

- Specification ~~ behavioral description
 - input/output timing fixed – handshaking signals & clock

```
process -- gcd-bhv.vhdl
  variable x, y: unsigned(15 downto 0);
begin
  -- Wait for the new input data
  wait on clk until clk='1' and rst='0';
  x := xi;    y := yi;    rdy <= '0';
  wait on clk until clk='1';
  -- Calculate
  while x /= y loop
    if x < y then y := y - x;
    else          x := x - y;    end if;
  end loop;
  -- Ready
  xo <= x;    rdy <= '1';
  wait on clk until clk='1';
end process;
```

Problems

- inner loop not clocked
- complex wait statement
- (- multiple wait statements)

What to look for?

- different synthesis tools
- minimizing resources
- maximizing performance

Target technologies – ASIC, FPGA

VHDL code & testbenches

<http://mini.pld.ttu.ee/~lrv/gcd/gcd.html>



GCD example – synthesizable code?

- Clocked behavioral style

```
process -- gcd-bhvc.vhdl
  variable x, y: unsigned(15 downto 0);
begin
  -- Wait for the new input data
  while rst = '1' loop
    wait on clk until clk='1';
  end loop;
  x := xi;    y := yi;    rdy <= '0';
  wait on clk until clk='1';
  -- Calculate
  while x /= y loop
    if x < y then y := y - x;
    else        x := x - y;    end if;
    wait on clk until clk='1';
  end loop;
  -- Ready
  xo <= x;    rdy <= '1';
  wait on clk until clk='1';
end process;
```

ASIC: synthesizable

961 e.g. / 20.0 ns

2 sub-s, 2 comp-s

FPGA: non-synthesizable

wait statements in loops :(

explicit FSM needed :(:(

Possible trade-offs

- functional unit sharing

- universal functional units

- out-of-order execution



GCD example – behavioral FSM

```
process begin -- gcd-bfsm.vhdl
  wait on clk until clk='1';
  case state is
  -- Wait for the new input data
  when S_wait =>
    if rst='0' then
      x<=xi; y<=yi; rdy<='0'; state<=S_start;
    end if;
  -- Calculate
  when S_start =>
    if x /= y then
      if x < y then y <= y - x;
      else x <= x - y; end if;
      state<=S_start;
    else
      xo<=x; rdy<='1'; state<=S_ready;
    end if;
  -- Ready
  when S_ready => state<=S_wait;
  end case;
end process;
```

ASIC: synthesizable

911 e.g. / 19.4 ns

2 sub-s, 2 comp-s

FPGA: synthesizable

108 SLC / 9.9 ns

2 sub-s, 2 comp-s

Can it be made better?

Again the possible trade-offs

- functional unit sharing

one operation per clock step

- universal functional units

$A < B == A - B < 0$ / $A /= B == A - B /= 0$

- out-of-order execution

subtracting first then deciding

GCD example

Clocked behavioral

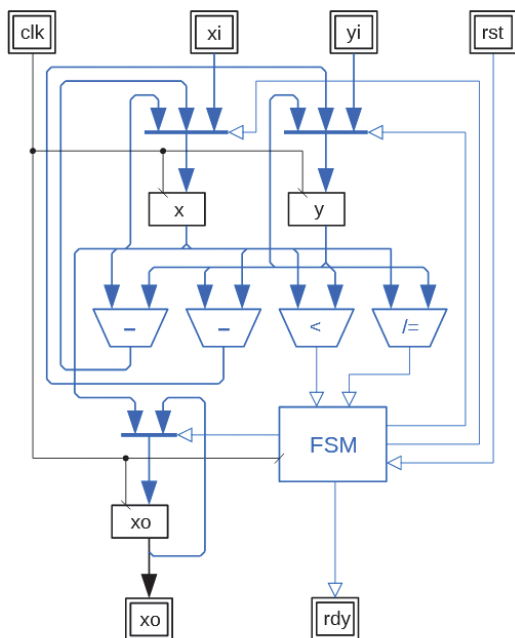

Only registers (signals) are described explicitly.

The rest (datapath & FSM) are described implicitly – subject for interpretations by synthesizers.

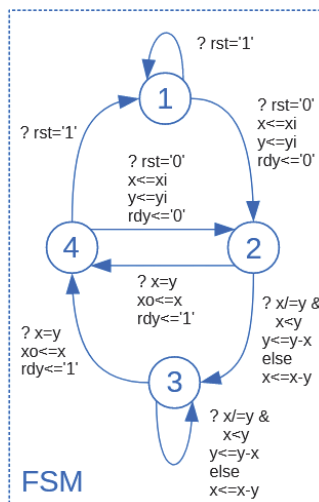

Code: gcd-bhvc.vhdl

2 subtractors, 2 comparators
[1 clock step per iteration]

ASIC: 961 e.g. / 20.0 ns
FPGA: not synthesizable

Behavioral FSM

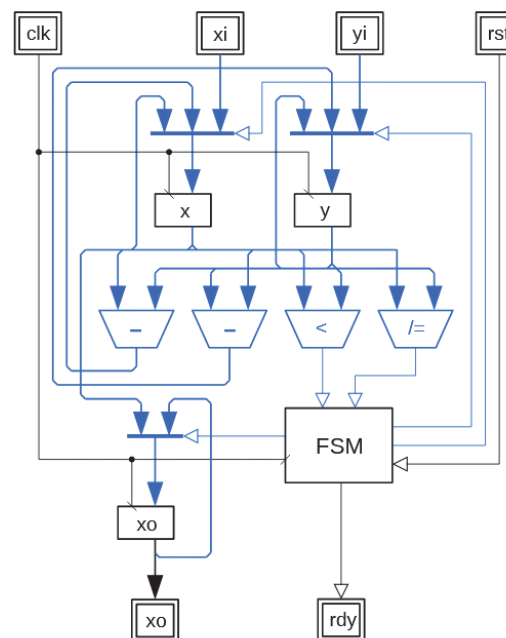

Registers (signals) and FSM are described explicitly.

The datapath is described implicitly – subject for interpretations by synthesizers.

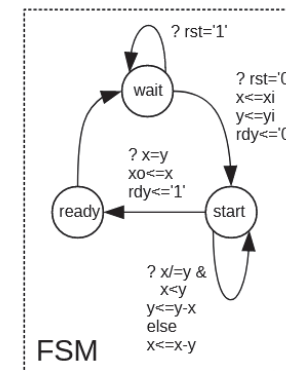

Code: gcd-bfsm.vhdl

2 subtractors, 2 comparators
[1 clock step per iteration]

ASIC: 911 e.g. / 19.4 ns
FPGA: 108 SLC / 9.9 ns

GCD example – universal functional units?

- $A < B \iff A - B < 0$ / $A = B \iff A - B = 0$

-- Three operations:

-- subtraction, and

-- comparisons not-equal &

-- less-than

`xo <= xi - yi;`

`ne <= '1' when xi /= yi else '0';`

`lt <= '1' when xi < yi else '0';`

ASIC: 209 e.g. / 19.9 ns

FPGA: 20 SLC / 12.1 ns

three adder chains!

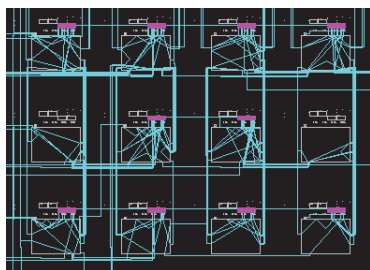

-- ALU - subtracting and then comparing

`x_out <= xi - yi; xo <= x_out;`

`process (x_out)`

`variable or_tmp: unsigned(15 downto 0);`

`begin`

`or_tmp(15) := x_out(15);`

`for i in 14 downto 0 loop`

`or_tmp(i) := or_tmp(i+1) or x_out(i);`

`end loop;`

`ne <= to_bit(or_tmp(0));`

`end process;`

`lt <= to_bit(x_out(15));`

ASIC: 148 e.g. / 21.8 ns / FPGA: 12 SLC / 14.6 ns

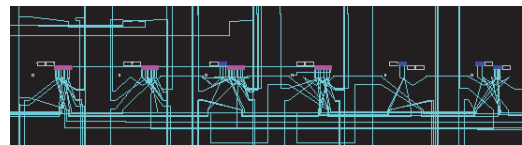



GCD example – design space exploration

- **Different solutions – <http://mini.pld.ttu.ee/~lrv/gcd/gcd.html>**
 - **gcd-bhv.vhdl – pure behavioral description, non-synthesizable**
 - **gcd-bhvc.vhdl – fully clocked behavioral style, some synthesis tools can handle**
 - **gcd-bfsm.vhdl – so called behavioral FSM (explicit FSM & behavioral data-path), synthesizable (but how efficient it is?)**
 - **gcd-rtl1.vhdl – single ALU, 3 clock cycles per iteration –
1) “not equal?”, 2) “less than?”, 3) subtract**
 - **gcd-rtl2.vhdl – single ALU, 2 clock cycles per iteration –
1) “not equal?” and “less than?”, 2) subtract**
 - **gcd-rtl3.vhdl – comparator (less than) controls subtraction, 1 clock cycle per iteration –
small but slow (sequential) data-path**
 - **gcd-rtl4.vhdl – out-of-order execution – both subtractions are calculated first then the decision is made (one subtracter compares for “less than”, another for “not equal”)**
 - **gcd-rtl5.vhdl – out-of-order execution – both subtractions are calculated first then the decision is made (one subtracter compares for “less than” but separate “not equal”)**



GCD example – single ALU, 2 clock cycles per iteration

gcd-rtl2.vhdl

```
-- Next state function of the FSM
process (state, rst, alu_ne, alu_lt) begin
  ena_x <= '0';    ena_y <= '0';    ena_r <= '0';
  set_rdy <= '0';  xi_yi_sel <= '0';  sub_y_x <= '0';
  next_state <= state;
  case state is
  when S_wait =>    -- Wait for the new input data
    if rst='0' then
      xi_yi_sel <= '1';  ena_x <= '1';  ena_y <= '1';
      next_state <= S_start;
    end if;
  when S_start =>   -- Loop: ready?
    if alu_ne='1' then
      if alu_lt='1' then  next_state <= S_sub_y_x;
      else  next_state <= S_sub_x_y;  end if;
    else  next_state <= S_ready;
    end if;
  when S_sub_y_x =>  -- Loop: y-x
    ena_y <= '1';    sub_y_x <= '1';
    next_state <= S_start;
  when S_sub_x_y =>  -- Loop: x-y
    ena_x <= '1';    sub_y_x <= '0';
    next_state <= S_start;
  when S_ready =>   -- Ready
    ena_r <= '1';    set_rdy <= '1';
    next_state <= S_wait;
  end case;
end process;

-- ALU: subtract / less-than / not-equal
alu_o <= alu_1 - alu_2;
alu_lt <= to_bit(alu_o(15));
process (alu_o)
  variable or_tmp: unsigned(15 downto 0);
begin
  or_tmp(15) := alu_o(15);
  for i in 14 downto 0 loop
    or_tmp(i) := or_tmp(i+1) or alu_o(i);
  end loop;
  alu_ne <= to_bit(or_tmp(0));
end process;

-- Multiplexers
x_i <= xi when xi_yi_sel='1' else alu_o;
y_i <= yi when xi_yi_sel='1' else alu_o;
alu_1 <= y when sub_y_x='1' else x;
alu_2 <= x when sub_y_x='1' else y;

-- Registers
process begin
  wait on clk until clk='1';
  state <= next_state;
  if ena_x='1' then  x <= x_i;    end if;
  if ena_y='1' then  y <= y_i;    end if;
  if ena_r='1' then  xo <= x;     end if;
  rdy <= set_rdy;
end process;
```



GCD example – out-of-order execution (2 sub-s)

gcd-rtl5.vhdl

```
-- Next state function of the FSM
process (state, rst, alu_ne) begin
  ena_xy <= '0';      ena_r <= '0';
  set_rdy <= '0';    xi_yi_sel <= '0';
  next_state <= state;
  case state is
  -- Wait for the new input data
  when S_wait =>
    if rst='0' then
      xi_yi_sel <= '1';  ena_xy <= '1';
      next_state <= S_start;
    end if;
  -- Calculate
  when S_start =>
    if alu_ne='1' then
      ena_xy <= '1';
      next_state <= S_start;
    else
      ena_r <= '1';      set_rdy <= '1';
      next_state <= S_ready;
    end if;
  -- Ready
  when S_ready =>
    ena_r <= '1';      set_rdy <= '1';
    next_state <= S_wait;
  end case;
end process;

-- Subtractor (x-y) / comparator (x<y)
alu_o1 <= x - y;
sub_y_x <= '1' when alu_o1(alu_o1'high)='1' else '0';

-- Subtractor (y-x)
alu_o2 <= y - x;

-- Comparator (y/=x)
alu_ne <= '1' when x /= y else '0';

-- Multiplexers
x_i <= xi when xi_yi_sel='1' else alu_o1;
y_i <= yi when xi_yi_sel='1' else alu_o2;
ena_x <= '1' when (sub_y_x='0' and ena_xy='1') or
  xi_yi_sel='1' else '0';
ena_y <= '1' when (sub_y_x='1' and ena_xy='1') or
  xi_yi_sel='1' else '0';

-- Registers
process begin
  wait on clk until clk='1';
  state <= next_state;
  if ena_x='1' then  x <= x_i;  end if;
  if ena_y='1' then  y <= y_i;  end if;
  if ena_r='1' then  xo <= x;   end if;
  rdy <= set_rdy;
end process;
```

GCD example

Single ALU (RTL #2)

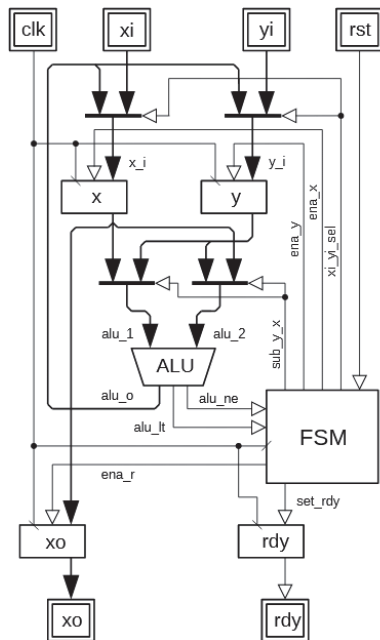

Register-transfer level description with universal ALU (operation reuse).

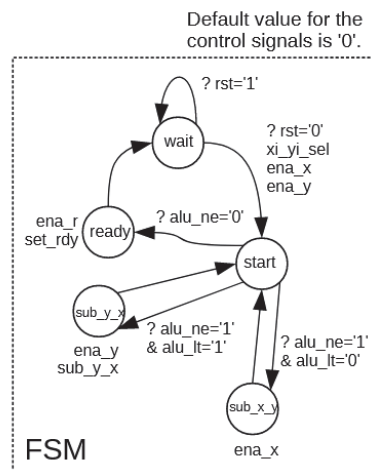

Code: gcd-rtl2.vhdl

Single ALU ("-", "<=", "/=")
[2 clock steps per iteration]

ASIC: 931 e.g. / 19.9 ns
FPGA: 48 SLC / 10.8 ns

Out-of-order execution (RTL #5)

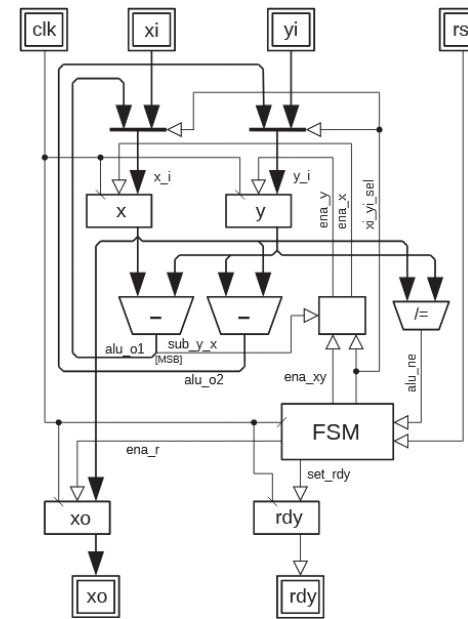

Register-transfer level description with out-of-order subtractions. Only data-path differs from RTL #3 & #4.

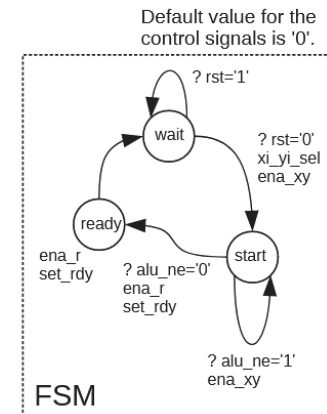

Code: gcd-rtl5.vhdl

2 subtractors, 1 comparator
[1 clock step per iteration]

ASIC: 915 e.g. / 20.0 ns
FPGA: 58 SLC / 8.0 ns



GCD example – synthesis results

Technology	FPGA				ASIC			
	50 MHz		100 MHz		50 MHz		25 MHz	
Constraint ¹⁾	[SLC]	[ns]	[SLC]	[ns]	[e.g.]	[ns]	[e.g.]	[ns]
<i>gcd-bhv²⁾</i>	93	17.3	-	-	1141	20.0	-	-
gcd-bhvc	-	-	-	-	961	20.0	977	31.1
gcd-bfsm	108	9.9	108	9.4	911	19.4	984	30.8
gcd-rtl1	50	10.8	50	9.7	986	19.8	883	32.4
gcd-rtl2	48	10.8	48	10.0	931	19.9	882	32.3
gcd-rtl3	58	17.0	58	14.6	1134	20.0	928	40.0
gcd-rtl4	78	12.6	78	9.0	976	19.9	928	29.0
gcd-rtl5	58	8.0	58	7.6	915	20.0	932	26.9

1) Clock period was the only constraint

2) gcd-bhv was synthesized using the help of prototype HLS tool xTractor



GCD example – why such differences?

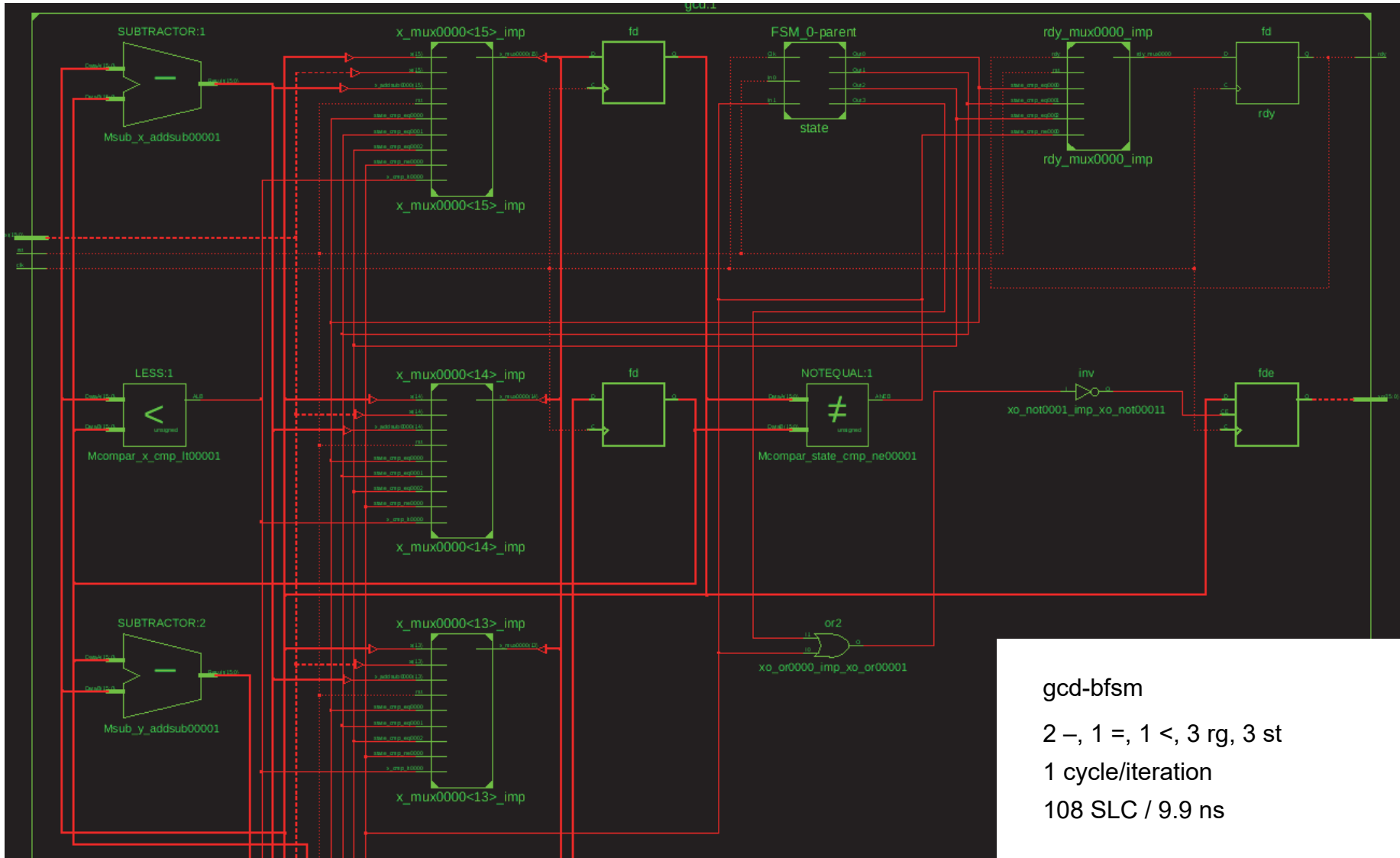

gcd-bfsm
 2 -, 1 =, 1 <, 3 rg, 3 st
 1 cycle/iteration
 108 SLC / 9.9 ns

GCD example – why such differences?

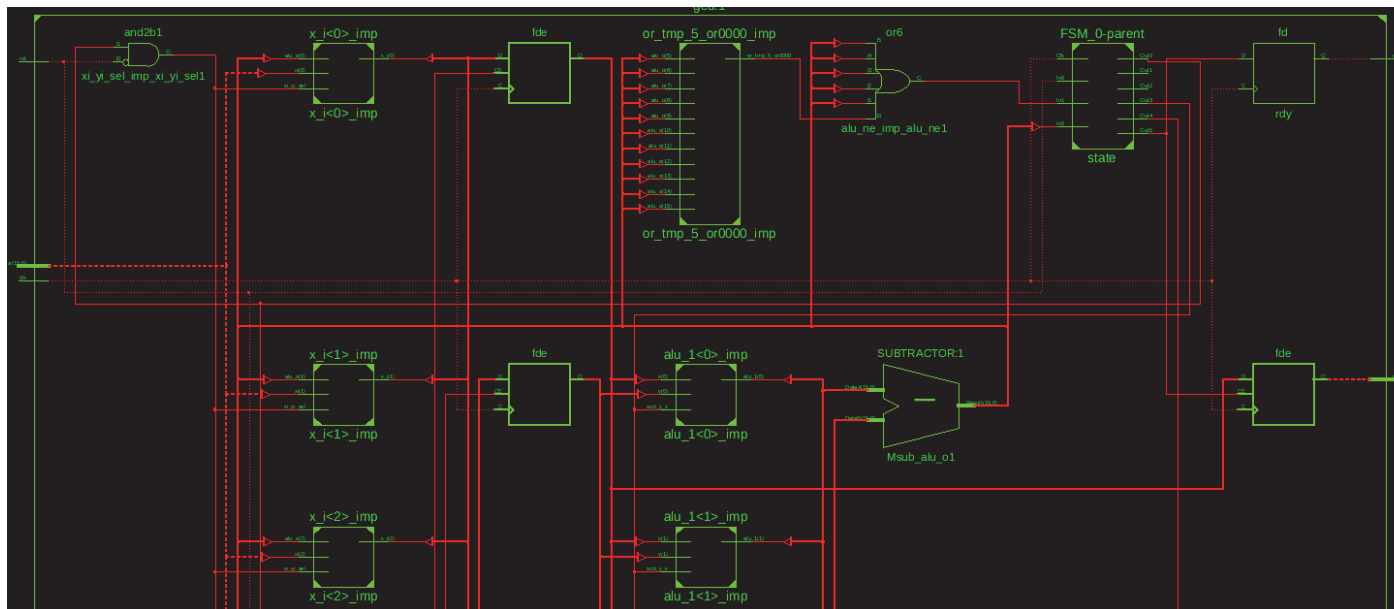

gcd-rtl1
 1 ALU, 3 rg, 6 st
 3 cycles/iteration
 50 SLC / 10.8 ns

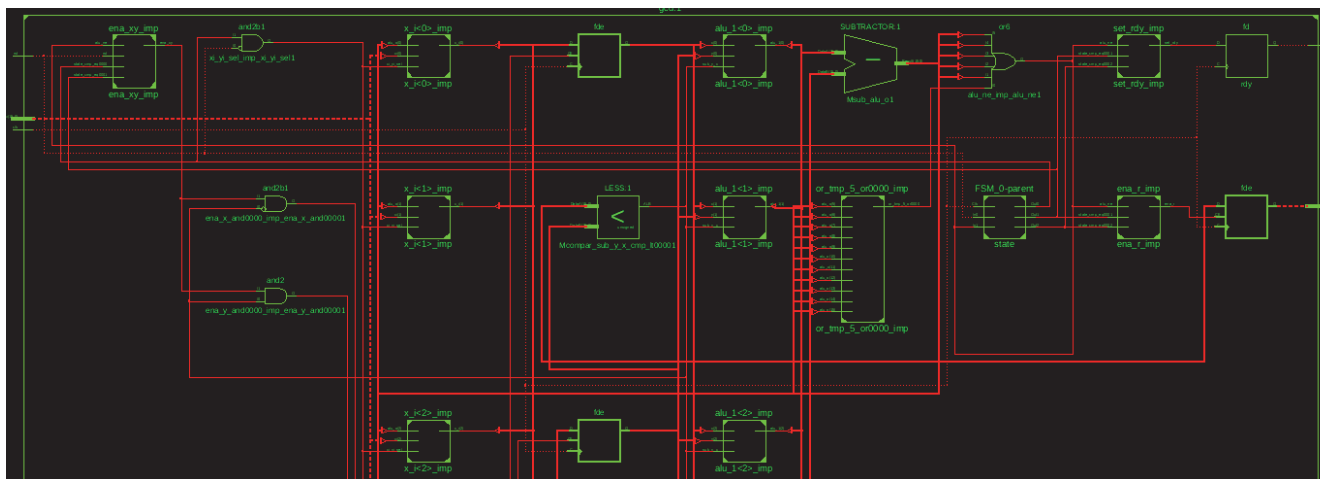

gcd-rtl2
 1 ALU, 3 rg, 5 st
 2 cycles/iteration
 48 SLC / 10.8 ns

gcd-rtl3
 1 -, 1 <, 3rg, 3st
 1 cycle/iteration
 58 SLC / 17.0 ns

GCD example – why such differences?

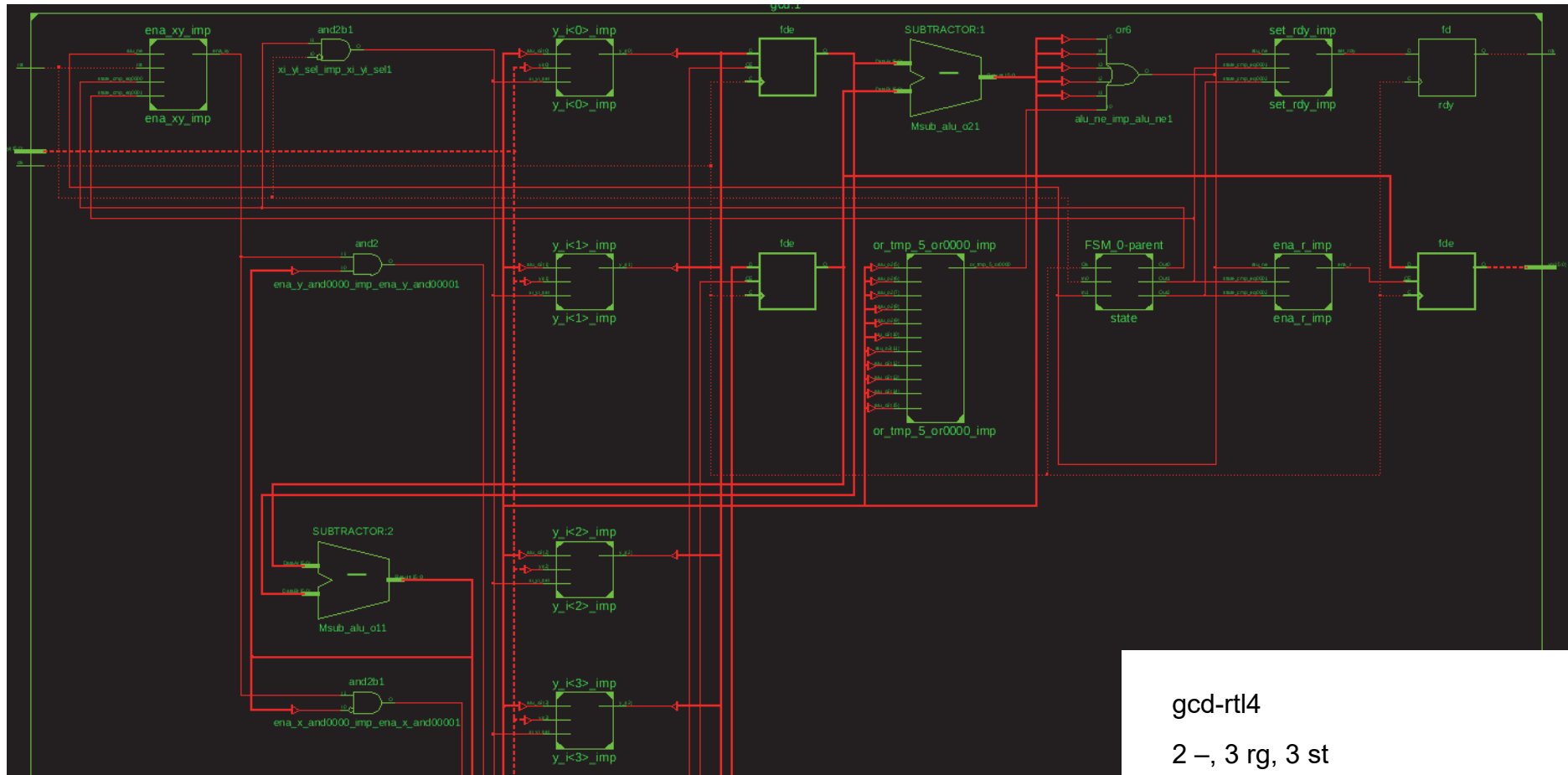

gcd-rtl4

2 –, 3 rg, 3 st

1 cycle/iteration

78 SLC / 12.6 ns

GCD example – why such differences?

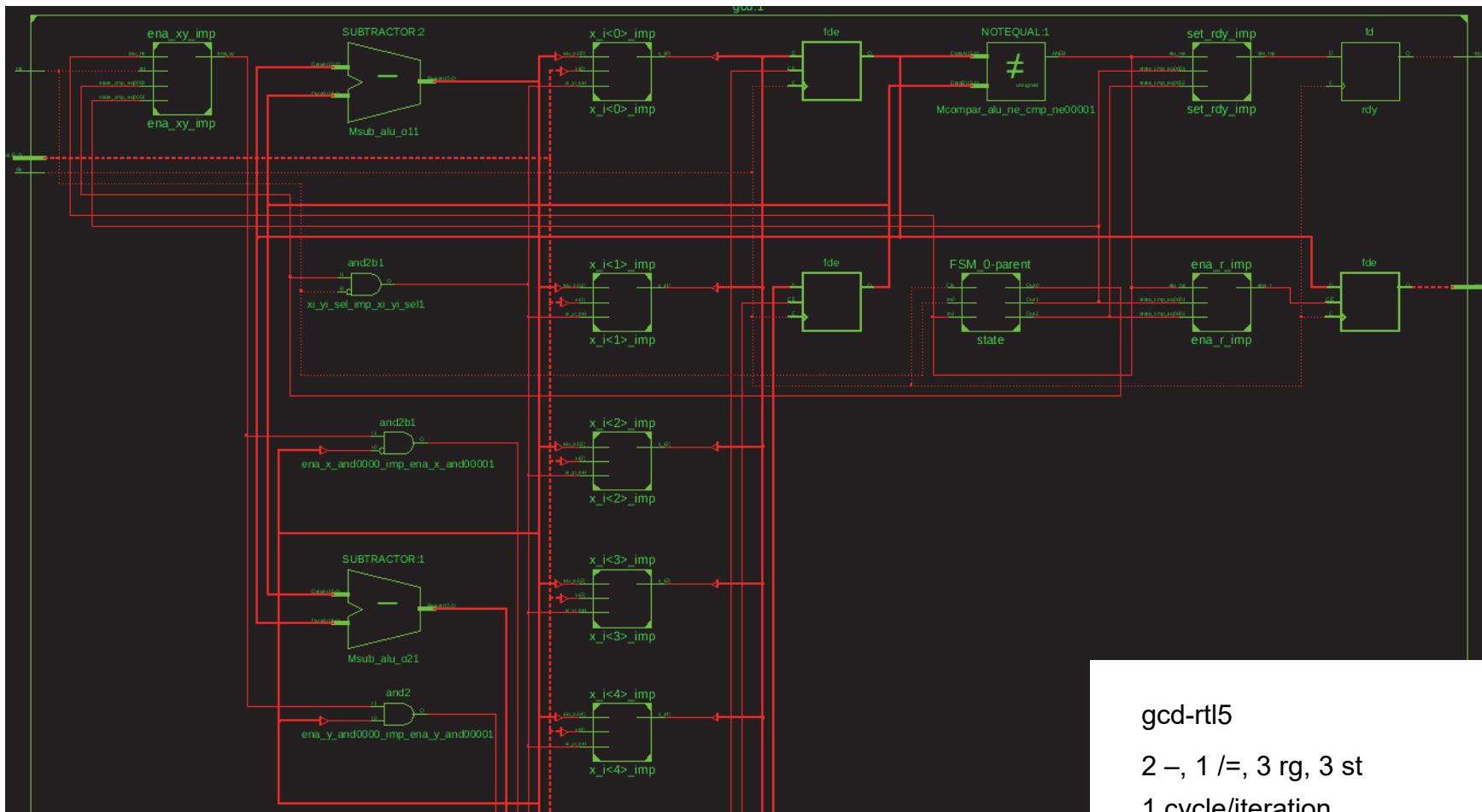

gcd-rtl5
 2 -, 1 /=, 3 rg, 3 st
 1 cycle/iteration
 58 SLC / 8.0 ns